

Quartz Crystal Resonators and Oscillators

For Frequency Control and Timing Applications - A Tutorial

January 2004

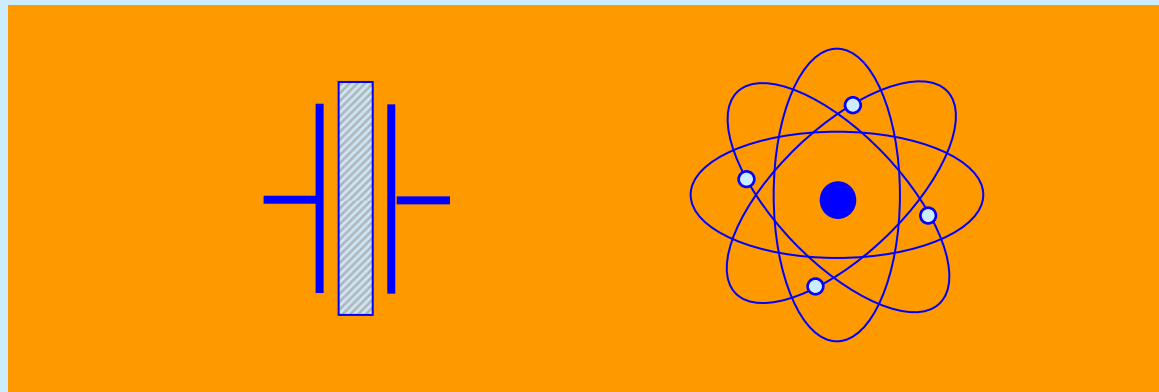

John R. Vig

US Army Communications-Electronics Research, Development & Engineering Center

Fort Monmouth, NJ, USA

J.Vig@IEEE.org

Approved for public release.
Distribution is unlimited

Acceleration vs. Frequency Change

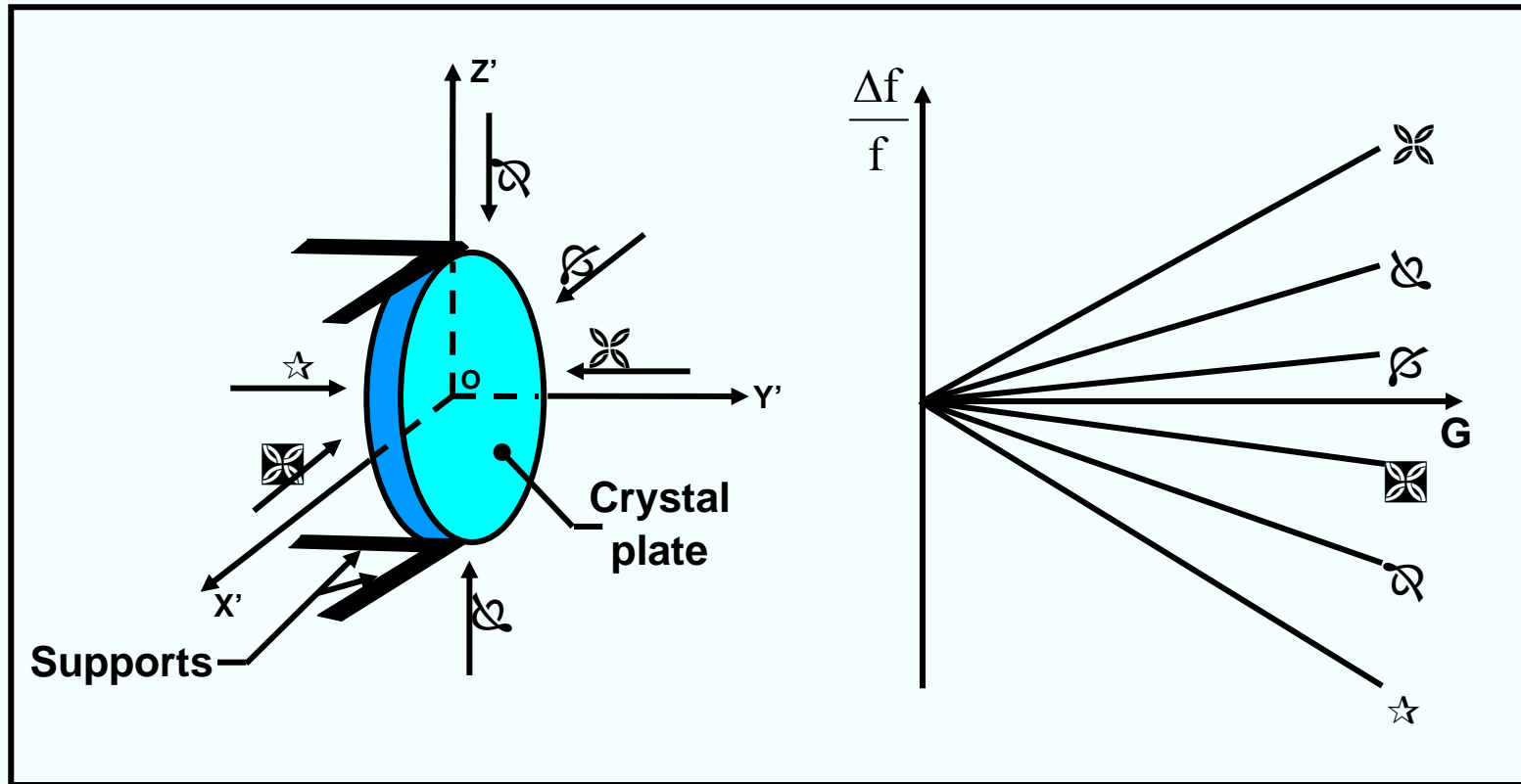

Frequency shift is a function of the magnitude and direction of the acceleration, and is usually linear with magnitude up to at least 50 g's.

2-g Tipover Test (Δf vs. attitude about three axes)

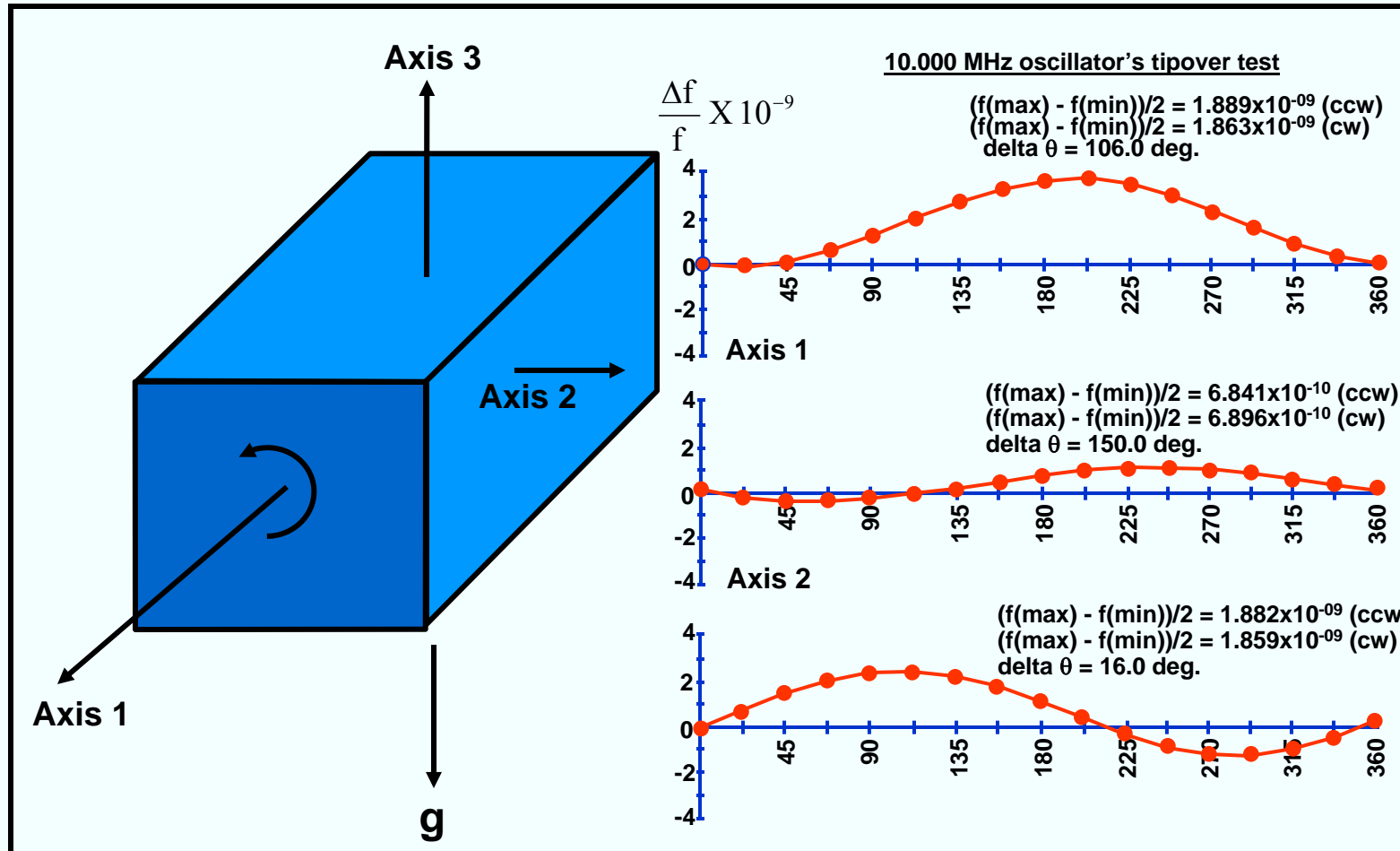

Sinusoidal Vibration Modulated Frequency

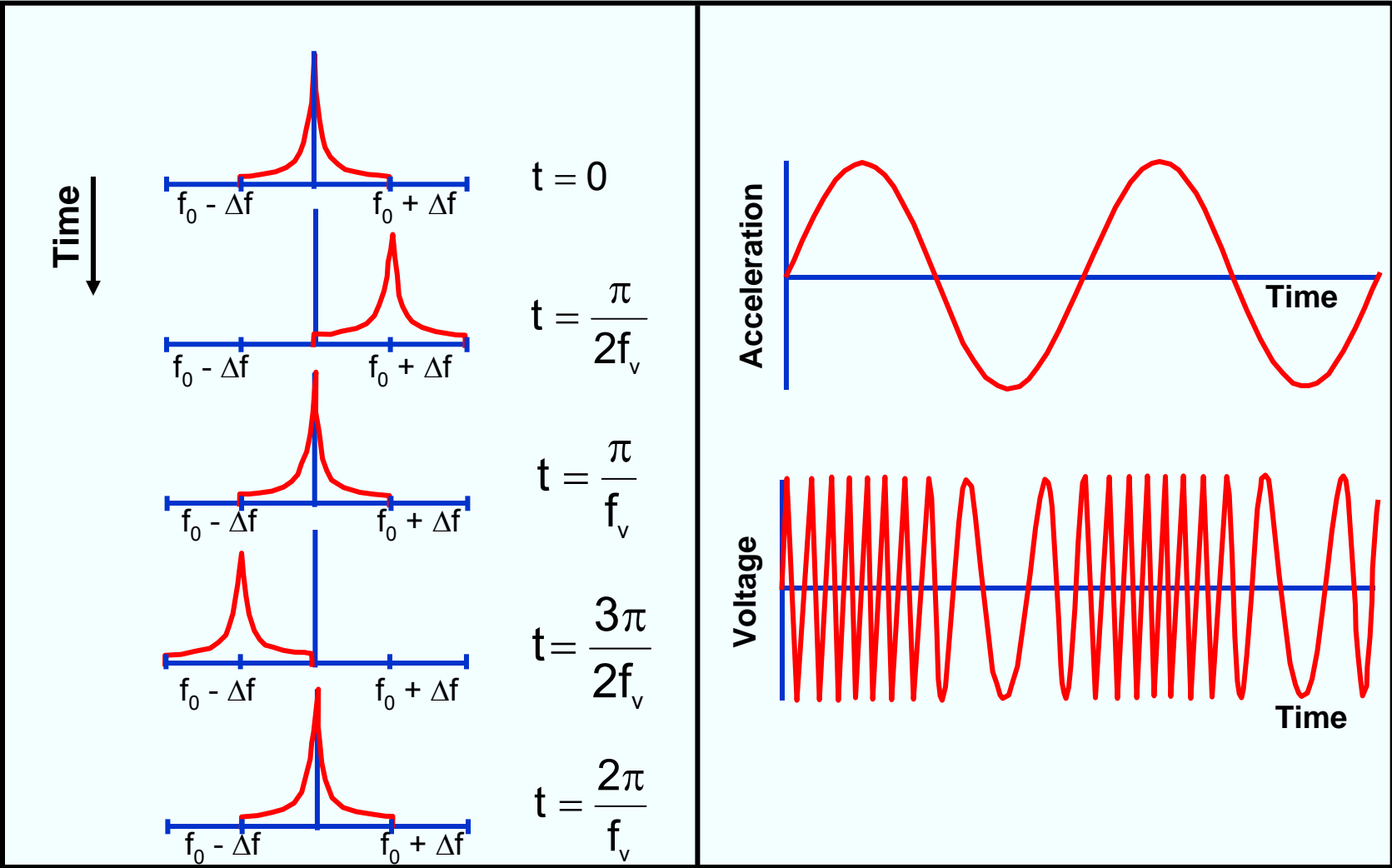

Acceleration Levels and Effects

Environment	Acceleration typical levels*, in g's	Δf x10⁻¹¹, for 1x10⁻⁹/g oscillator
Buildings**, quiescent	0.02 rms	2
Tractor-trailer (3-80 Hz)	0.2 peak	20
Armored personnel carrier	0.5 to 3 rms	50 to 300
Ship - calm seas	0.02 to 0.1 peak	2 to 10
Ship - rough seas	0.8 peak	80
Propeller aircraft	0.3 to 5 rms	30 to 500
Helicopter	0.1 to 7 rms	10 to 700
Jet aircraft	0.02 to 2 rms	2 to 200
Missile - boost phase	15 peak	1,500
Railroads	0.1 to 1 peak	10 to 100

* Levels at the oscillator depend on how and where the oscillator is mounted
Platform resonances can greatly amplify the acceleration levels.

** Building vibrations can have significant effects on noise measurements

Acceleration Sensitivity Vector

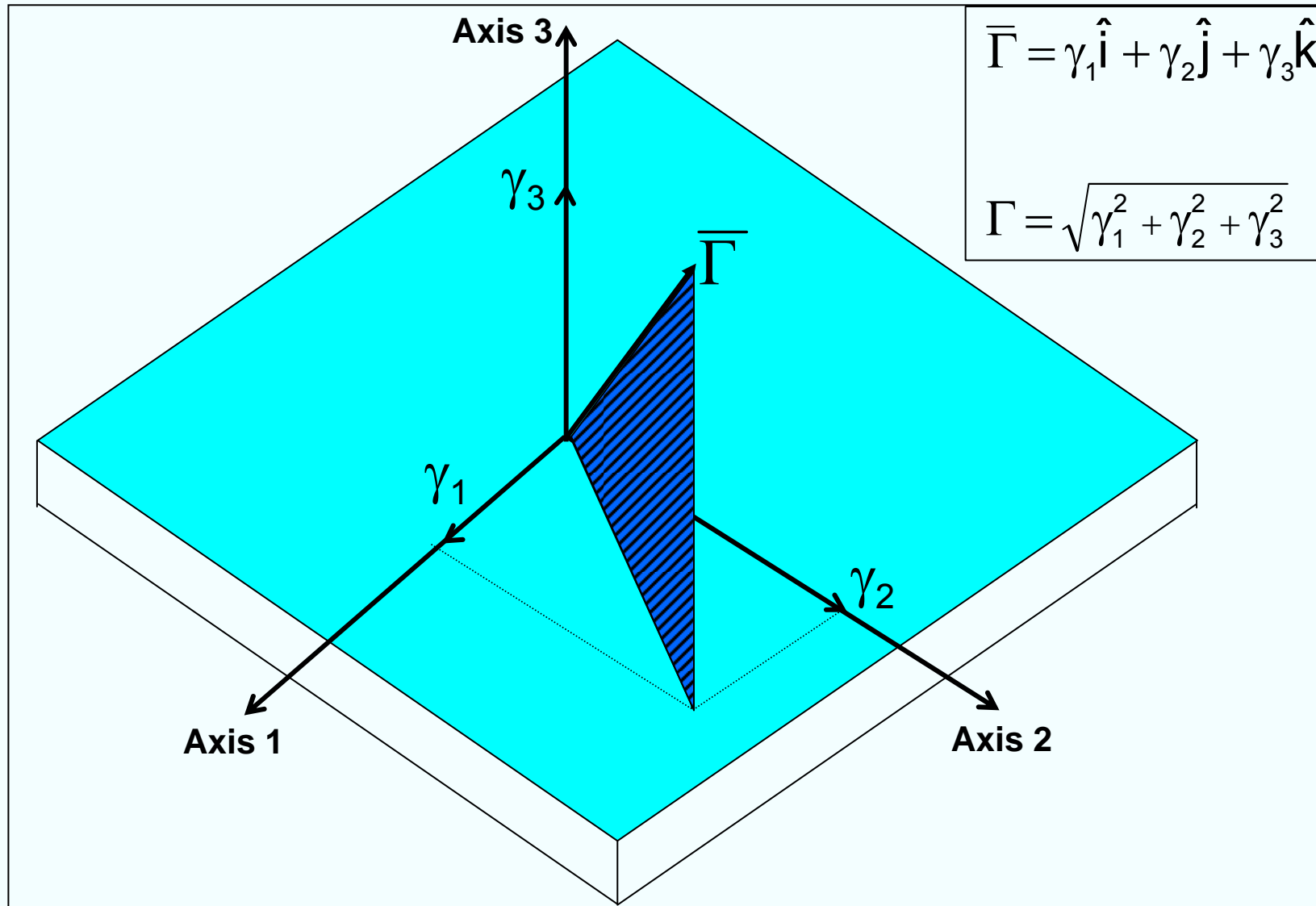

Vibration-Induced Allan Deviation Degradation

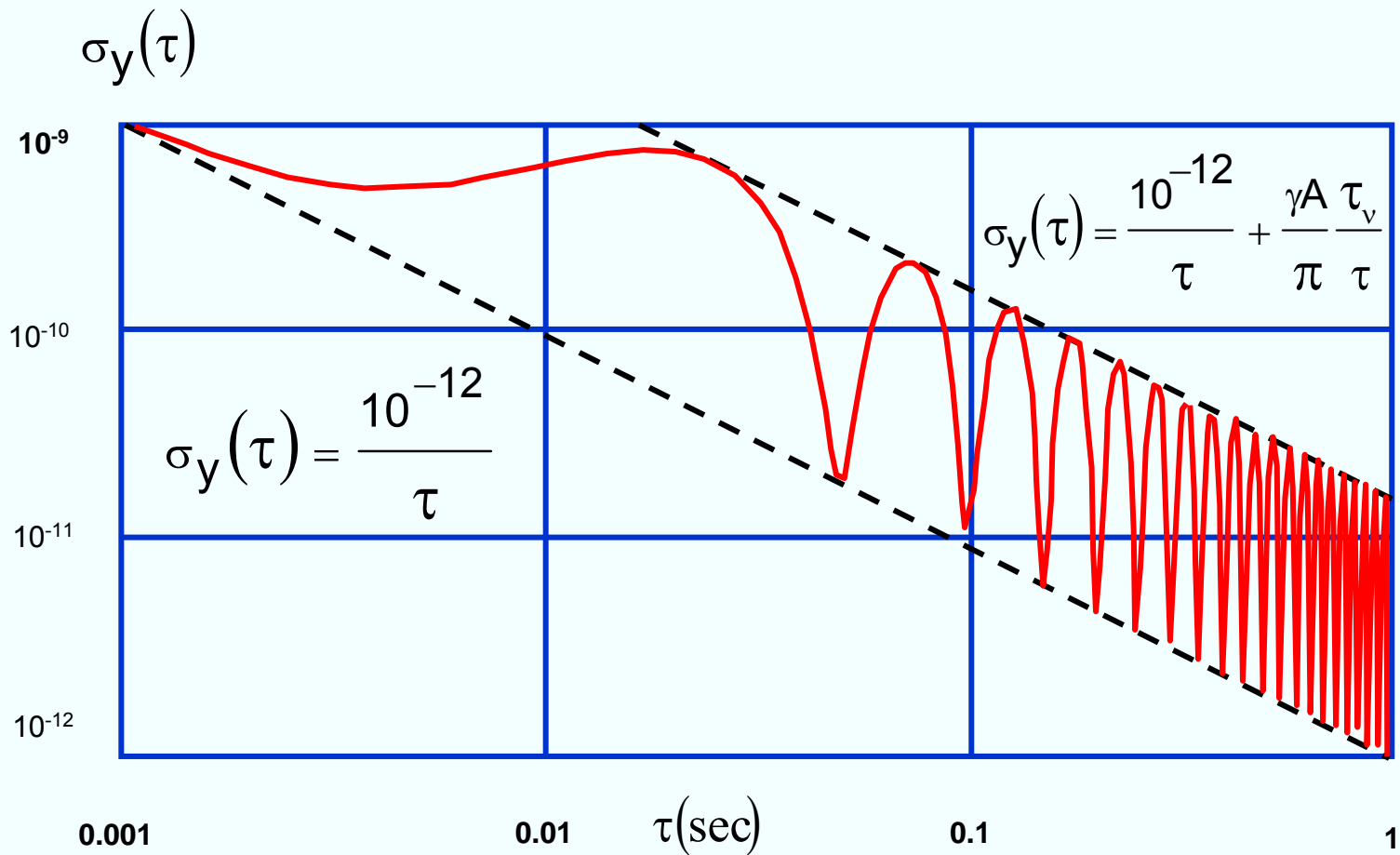

Example shown: $f_v = 20$, Hz $A = 1.0$ g along Γ , $|\Gamma| = 1 \times 10^{-9}/g$

Vibration-Induced Phase Excursion

The phase of a vibration modulated signal is

$$\varphi(t) = 2\pi f_0 t + \left(\frac{\Delta f}{f_v} \right) \sin(2\pi f_v t)$$

When the oscillator is subjected to a sinusoidal vibration, the peak phase excursion is

$$\Delta \varphi_{\text{peak}} = \frac{\Delta f}{f_v} = \frac{(\bar{\Gamma} \bullet \bar{A}) f_0}{f_v}$$

Example: if a 10 MHz, $1 \times 10^{-9}/g$ oscillator is subjected to a 10 Hz sinusoidal vibration of amplitude 1g, the peak vibration-induced phase excursion is 1×10^{-3} radian. If this oscillator is used as the reference oscillator in a 10 GHz radar system, the peak phase excursion at 10GHz will be 1 radian. Such a large phase excursion can be catastrophic to the performance of many systems, such as those which employ phase locked loops (PLL) or phase shift keying (PSK).

Vibration-Induced Sidebands

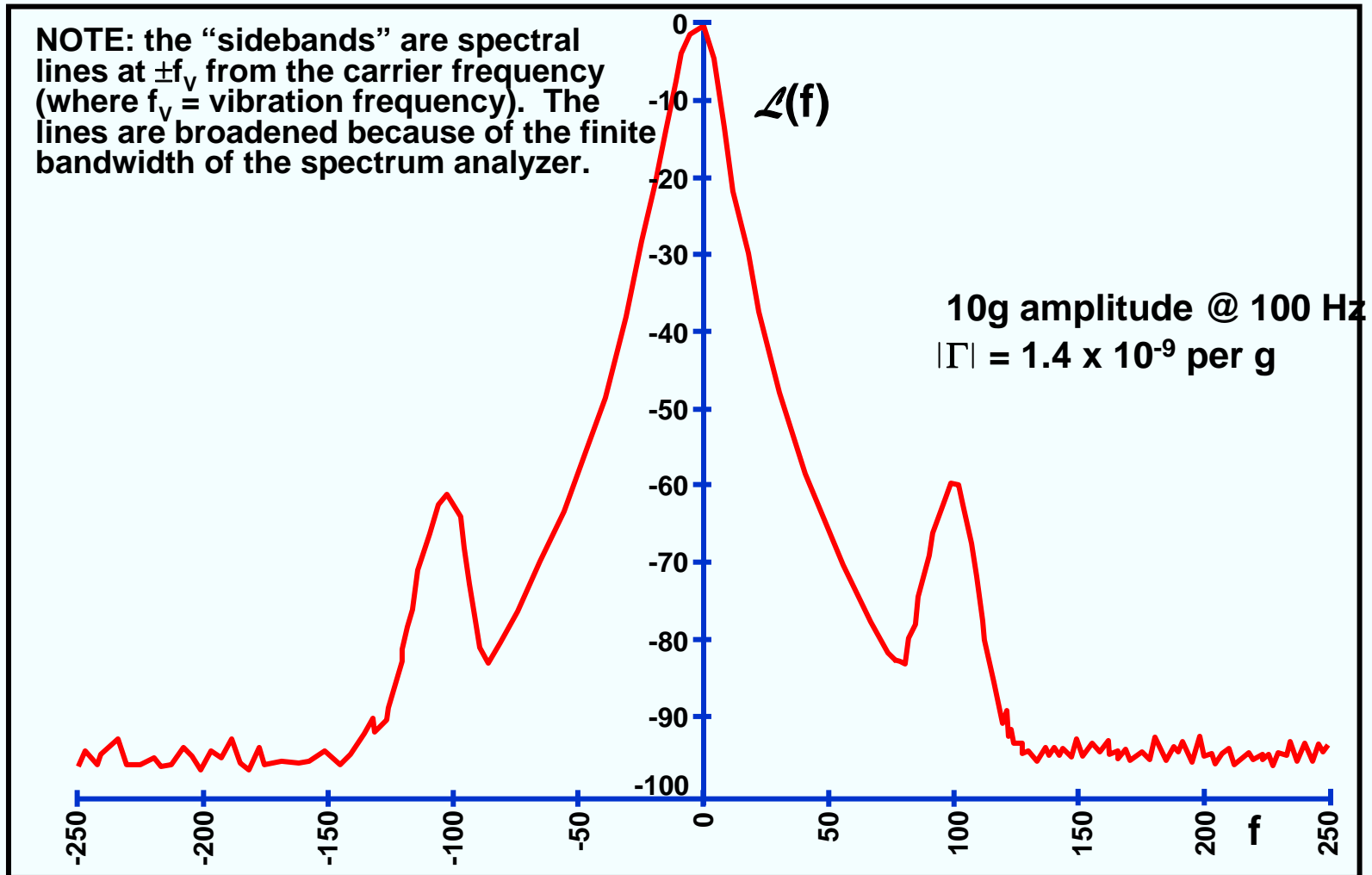

Vibration-Induced Sidebands

After Frequency Multiplication

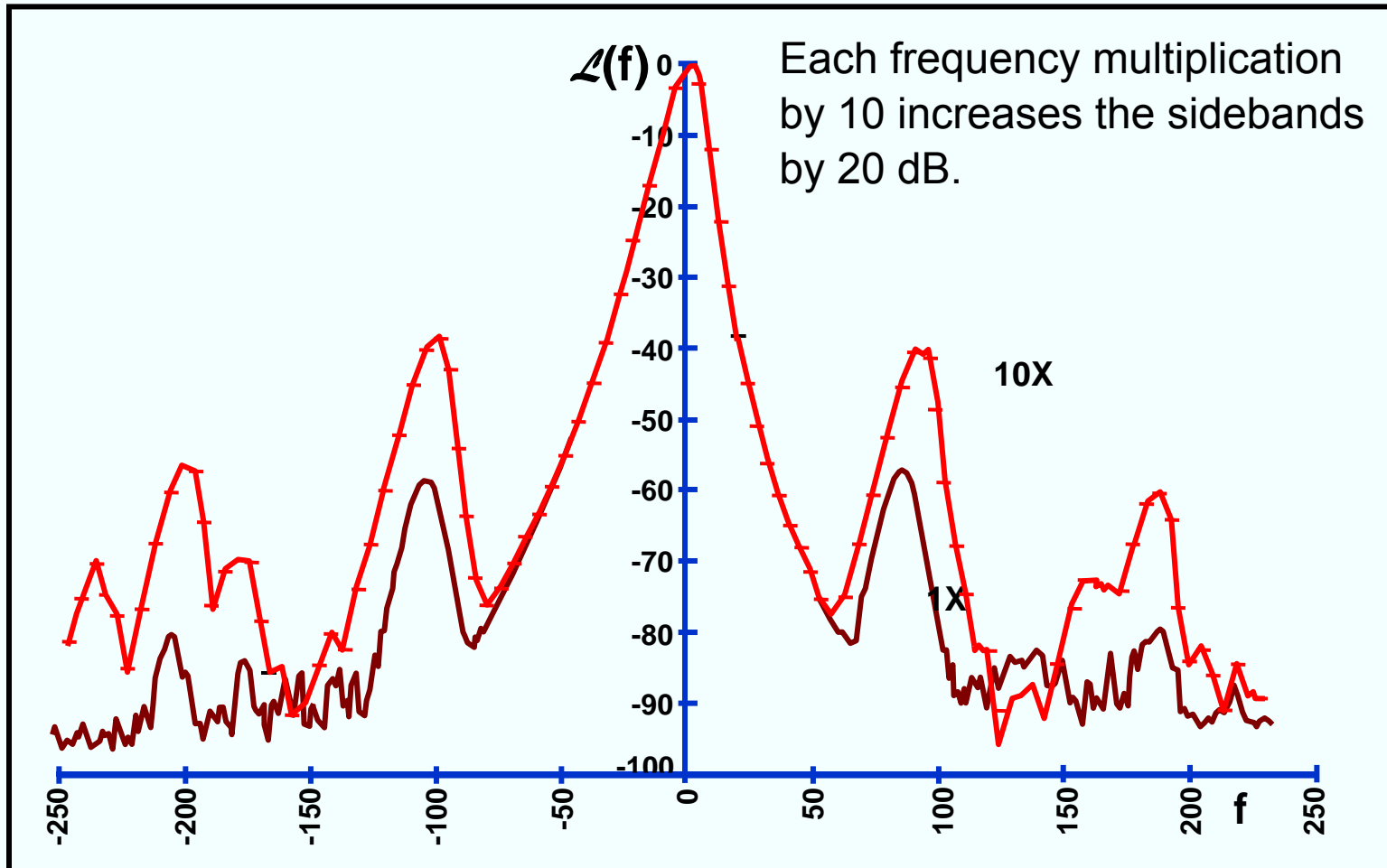

Sine Vibration-Induced Phase Noise

Sinusoidal vibration produces spectral lines at $\pm f_v$ from the carrier, where f_v is the vibration frequency.

$$\mathcal{L}(f_v) = 20 \log \left(\frac{\bar{\Gamma} \cdot \bar{A} f_0}{2f_v} \right)$$

e.g., if $|\bar{\Gamma}| = 1 \times 10^{-9}/g$ and $f_0 = 10$ MHz, then even if the oscillator is completely **noise free at rest**, the phase “noise” i.e., the spectral lines, due solely to a sine vibration level of 1g will be;

Vibr. freq., f_v , in Hz	$\mathcal{L}(f_v)$, in dBc
1	-46
10	-66
100	-86
1,000	-106
10,000	-126

Random Vibration-Induced Phase Noise

Random vibration's contribution to phase noise is given by:

$$\mathcal{L}(f) = 20 \log \left(\frac{\bar{\Gamma} \cdot \bar{A}f_0}{2f} \right), \quad \text{where } |\bar{A}| = [(2)(\text{PSD})]^{1/2}$$

e.g., if $|\bar{\Gamma}| = 1 \times 10^{-9}/g$ and $f_0 = 10 \text{ MHz}$, then even if the oscillator is completely **noise free at rest**, the phase “noise” i.e., the spectral lines, due solely to a vibration of power spectral density, $\text{PSD} = 0.1 \text{ g}^2/\text{Hz}$ will be:

Offset freq., f , in Hz	$\mathcal{L}'(f)$, in dBc/Hz
1	-53
10	-73
100	-93
1,000	-113
10,000	-133

Random-Vibration-Induced Phase Noise

Phase noise under vibration is for $\Gamma = 1 \times 10^{-9}$ per g and $f = 10$ MHz

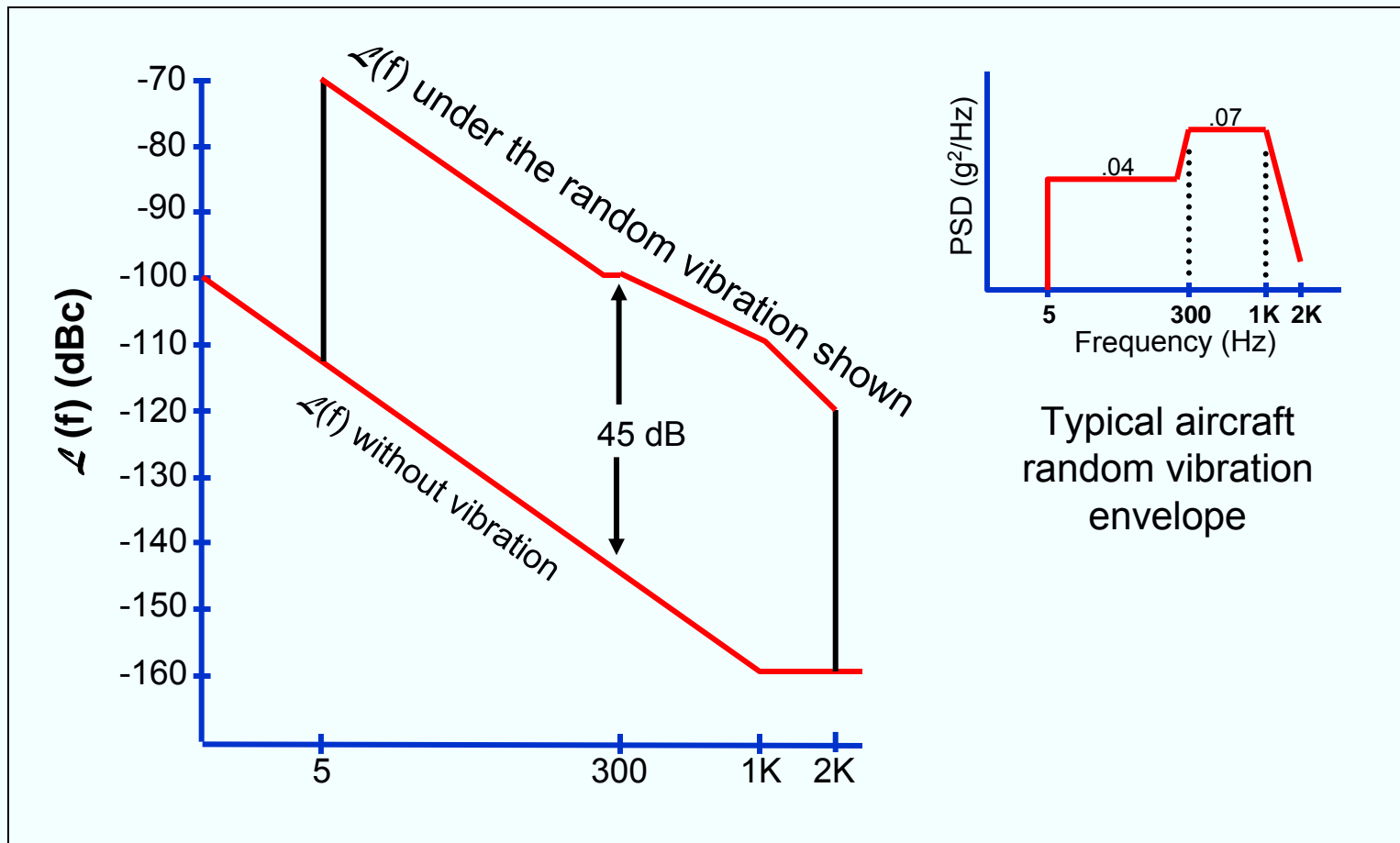

Acceleration Sensitivity vs. Vibration Frequency

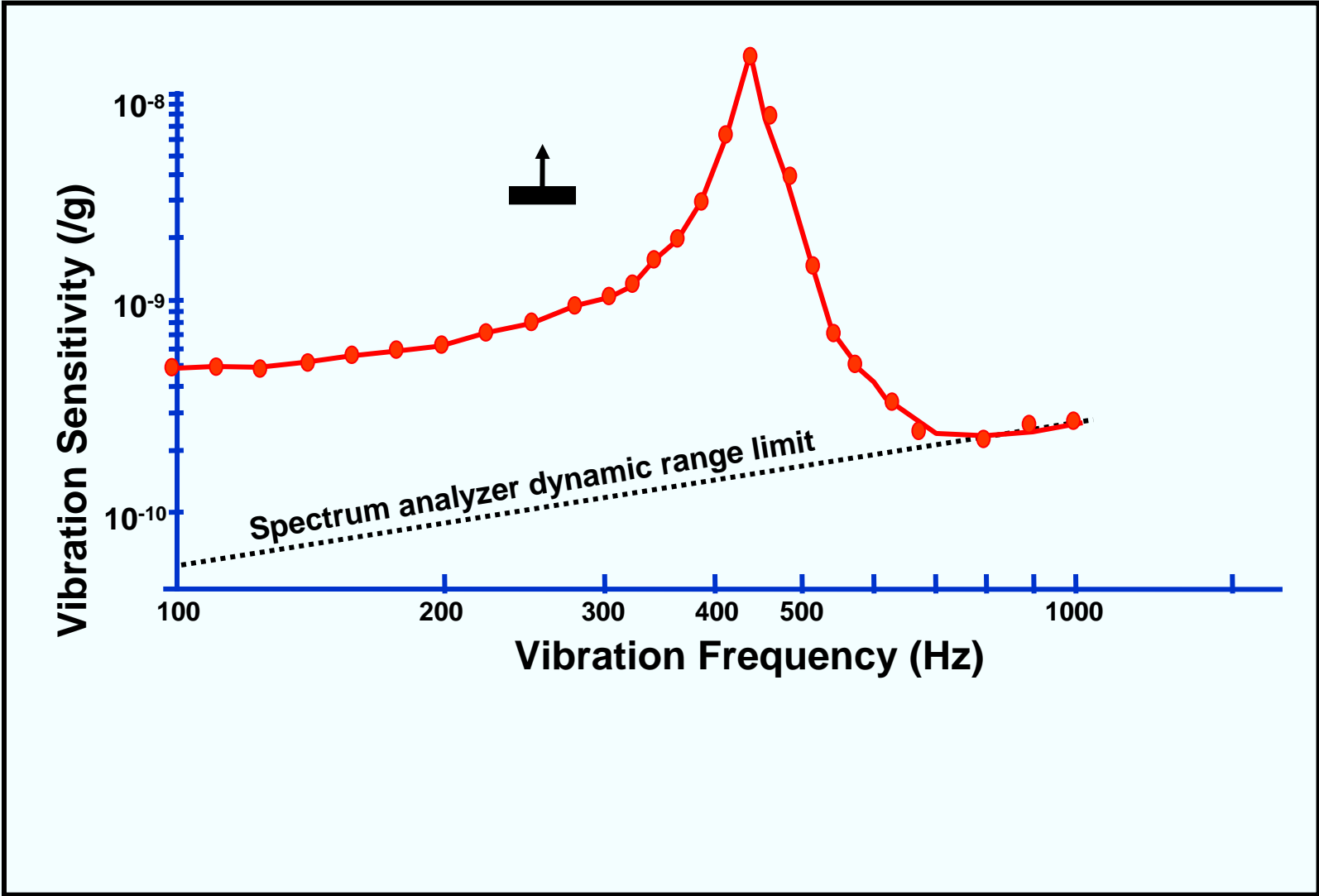

Acceleration Sensitivity of Quartz Resonators

Resonator acceleration sensitivities range from the low parts in 10^{10} per g for the best commercially available SC-cuts, to parts in 10^7 per g for tuning-fork-type watch crystals. When a wide range of resonators were examined: AT, BT, FC, IT, SC, AK, and GT-cuts; 5 MHz 5th overtones to 500 MHz fundamental mode inverted mesa resonators; resonators made of natural quartz, cultured quartz, and swept cultured quartz; numerous geometries and mounting configurations (including rectangular AT-cuts); nearly all of the results were within a factor of three of 1×10^{-9} per g. On the other hand, the fact that a few resonators have been found to have sensitivities of less than 1×10^{-10} per g indicates that the observed acceleration sensitivities are not due to any inherent natural limitations.

Theoretical and experimental evidence indicates that the major variables yet to be controlled properly are the mode shape and location (i.e., the amplitude of vibration distribution), and the strain distribution associated with the mode of vibration. Theoretically, when the mounting is completely symmetrical with respect to the mode shape, the acceleration sensitivity can be zero, but tiny changes from this ideal condition can cause a significant sensitivity. Until the acceleration sensitivity problem is solved, acceleration compensation and vibration isolation can provide lower than 1×10^{-10} per g, for a limited range of vibration frequencies, and at a cost.

Phase Noise Degradation Due to Vibration

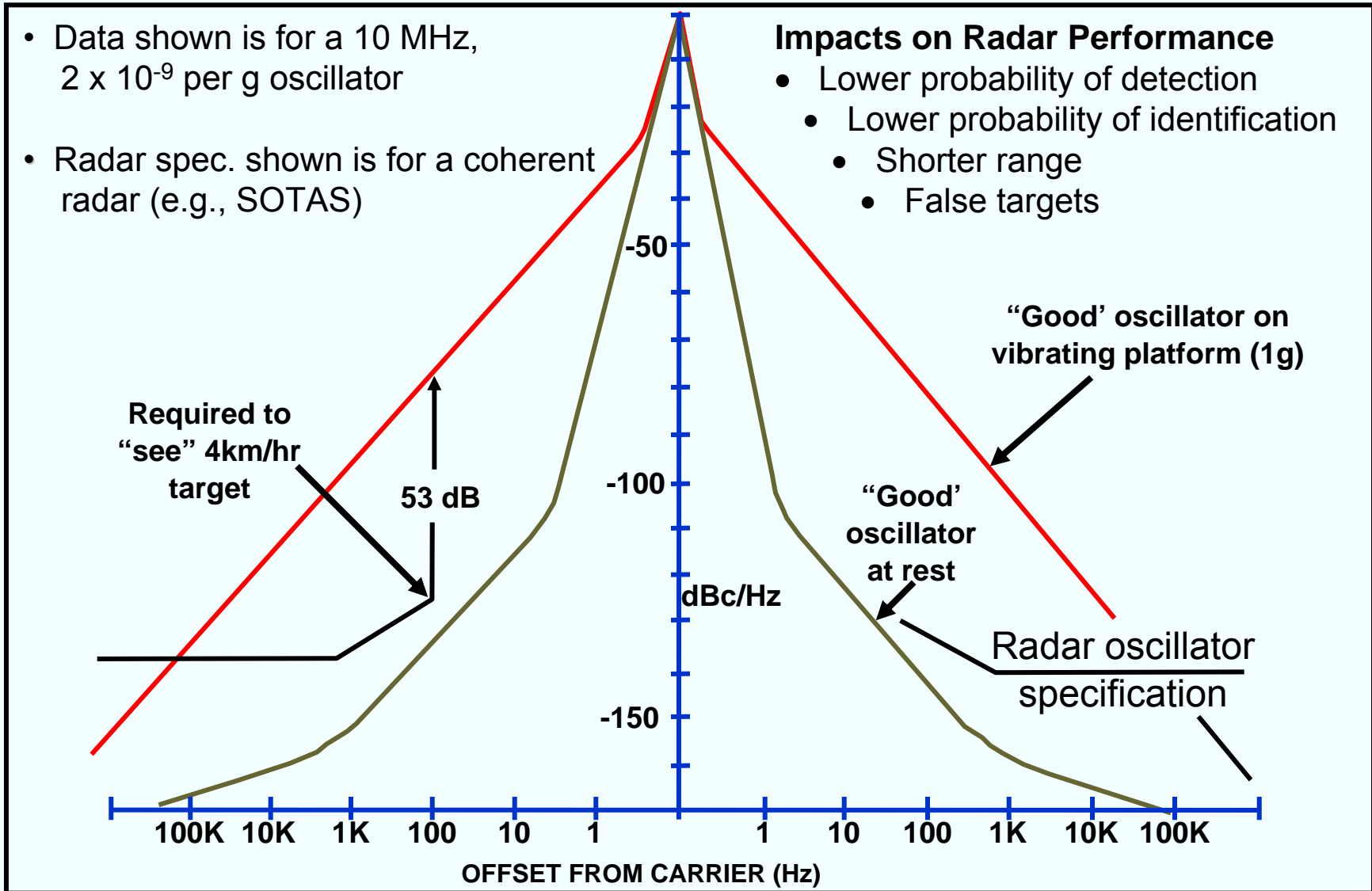

Coherent Radar Probability of Detection

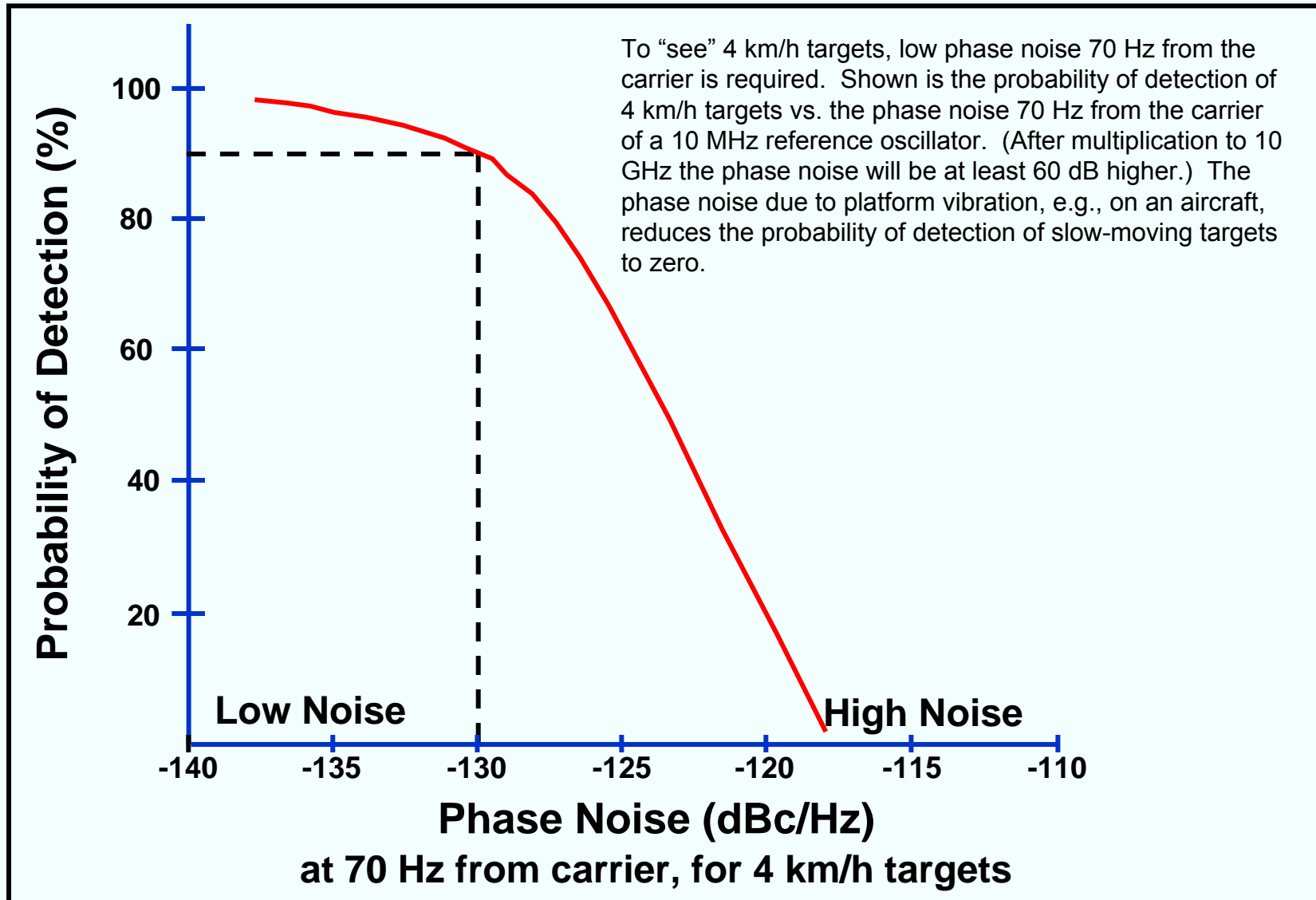

Vibration Isolation

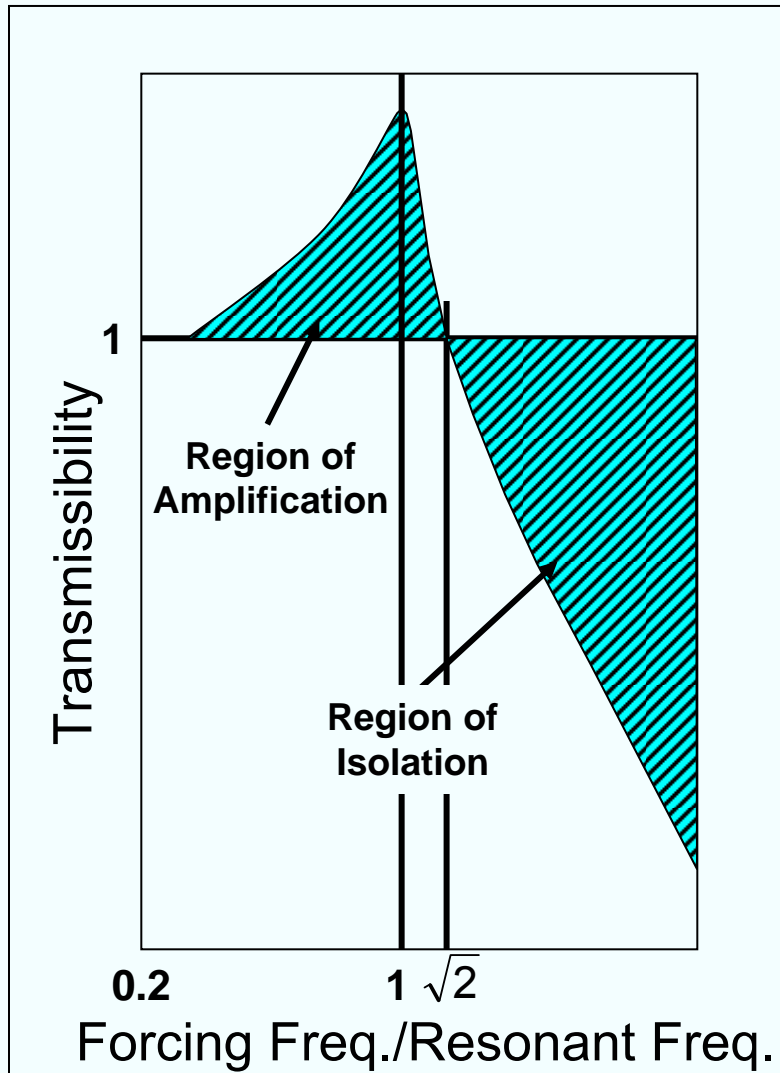

Limitations

- Poor at low frequencies
- Adds size, weight and cost
- Ineffective for acoustic noise

Vibration Compensation

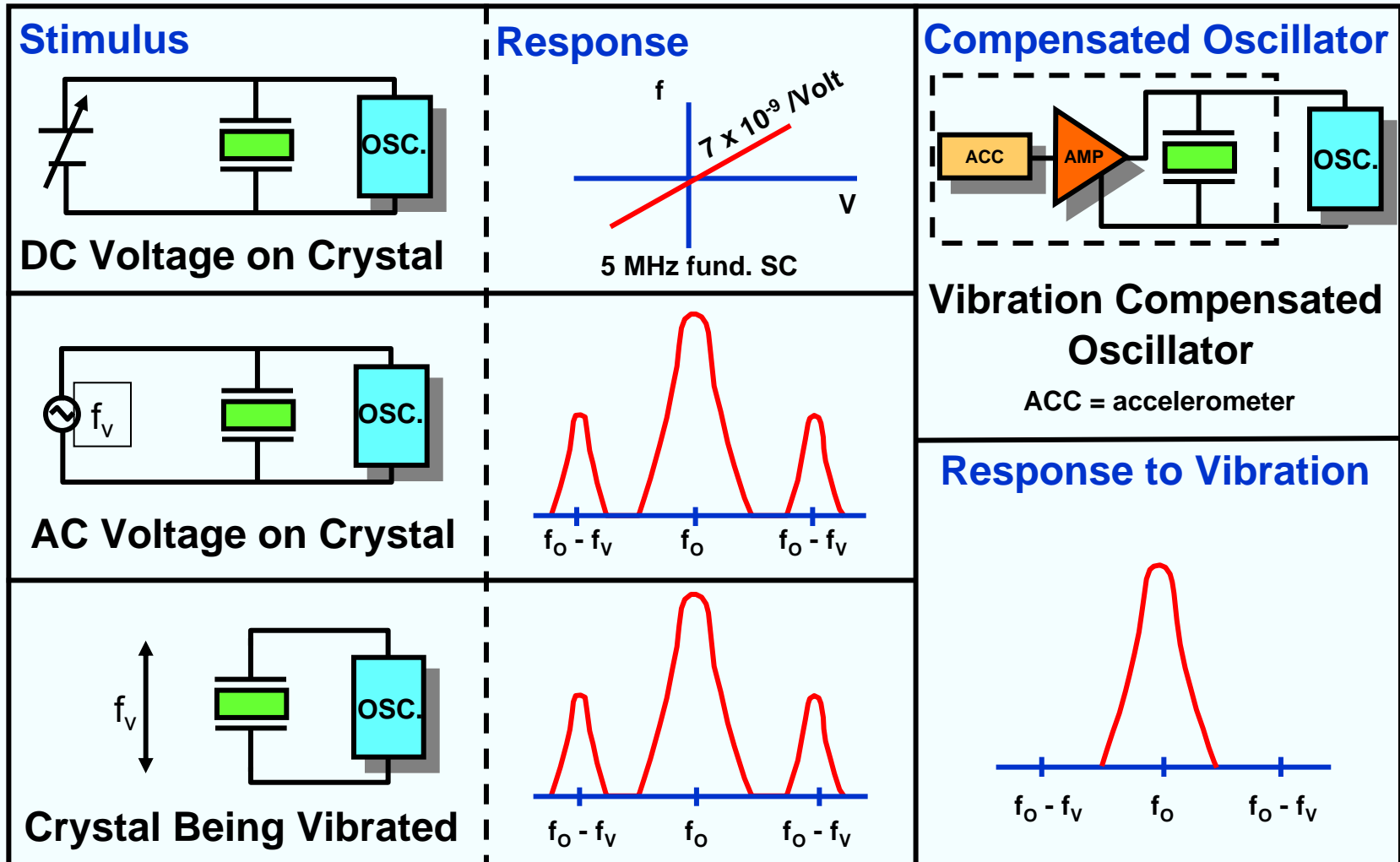

Vibration Sensitivity Measurement System

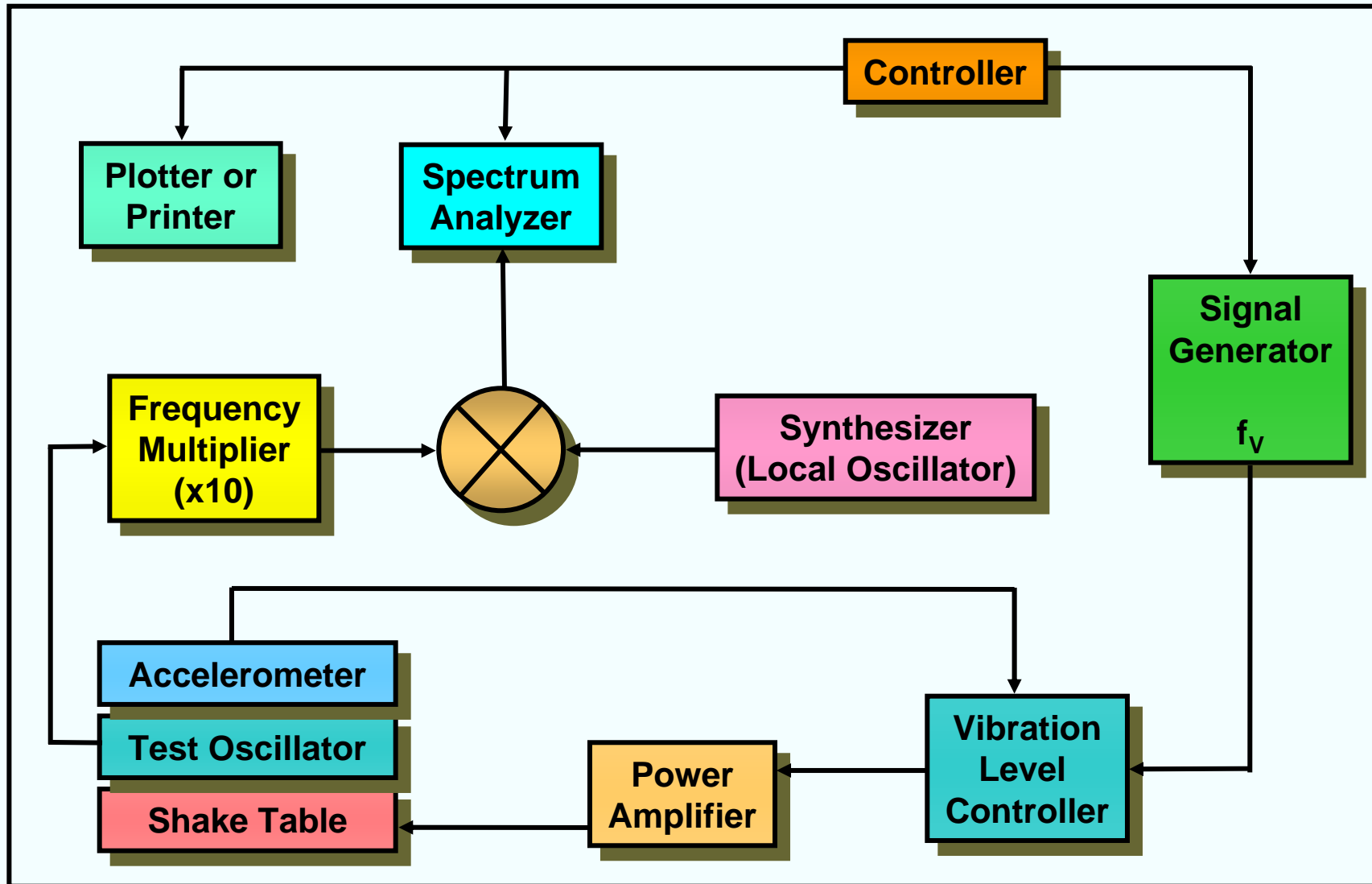

Shock

The frequency excursion during a shock is due to the resonator's stress sensitivity. The magnitude of the excursion is a function of resonator design, and of the shock induced stresses on the resonator (resonances in the mounting structure will amplify the stresses.) The permanent frequency offset can be due to: shock induced stress changes, the removal of (particulate) contamination from the resonator surfaces, and changes in the oscillator circuitry. Survival under shock is primarily a function of resonator surface imperfections. Chemical-polishing-produced scratch-free resonators have survived shocks up to 36,000 g in air gun tests, and have survived the shocks due to being fired from a 155 mm howitzer (16,000 g, 12 ms duration).

