



# CD-700/TRU050

## Code Mark Inversion (CMI) Input Data

### Introduction

The CD-700/TRU050 is a user-configured, phase-locked loop (PLL) solution designed to simplify a wide variety of clock recovery and data retiming, frequency translation, clock smoothing and clock switching applications. These timing needs are required by a wide variety of markets such as telecommunications, data communications, digital video and audio, telemetry, test equipment and sensing .

The primary application of the CD-700/TRU050 device is the extraction of a clock signal from an incoming Non-Return to Zero (NRZ) data stream. This data type is often utilized in optical telecom transmission. An example is shown in Figure 1 (a). NRZ data is a 1B1B code with one line bit for each associated binary bit. Although initially designed for NRZ timing recovery applications, the CD-700/TRU050 may be used for other data formats.

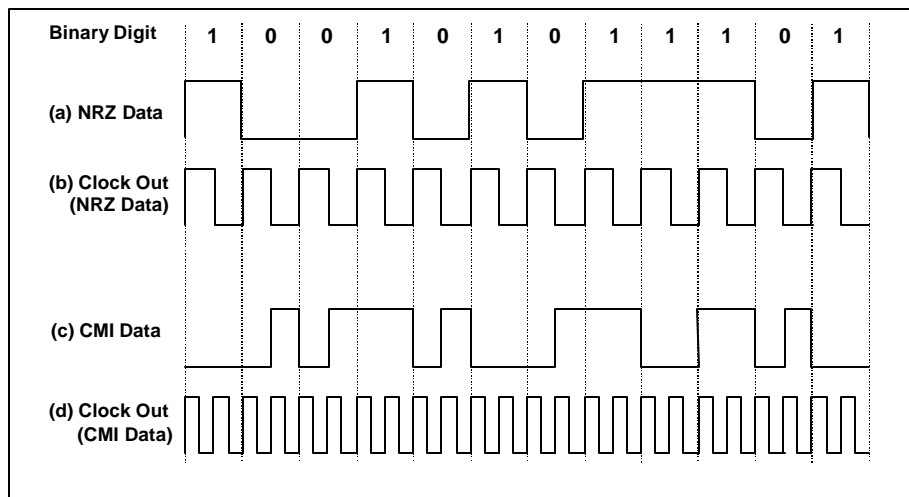

Figure 1

### CMI Input Data

In addition to NRZ data formats, the CD-700/TRU050 device is also commonly applied for clock extraction of input CMI data streams. CMI data is a 1B2B data format with two line bits for each associated binary bit.

As illustrated in Figure 1(c), a CMI low is represented by a positive transition in the center of the bit period. A CMI high is represented by no transition within the bit period, but with alternating polarity for each bit period. (A CMI low is transmitted as a 01, while a CMI high is either 11 or 00).

Because the CD-700/TRU050 was originally intended for NRZ applications, it will interpret an incoming CMI data stream as a NRZ stream at twice the binary rate. For this reason, when using the CD-700/TRU050 in CMI applications, the device should be tuned to twice the binary rate of the CMI data.

For example, a CD-700/TRU050 @ 38.88 Mb/s would be used to recover a clock signal from an input 19.44 Mb/s CMI data stream. Also note for CMI applications, that the resulting recovered clock will be twice the binary rate and may require division by 2. Divide by 2 option is available.

### For Additional Information Please Contact:

#### Vectron International, Incorporated

267 Lowell Road × Hudson, NH 03051 × Tel: 1-88-VECTRON-1 × Fax: 1-888-FAX-VECTRON  
e-mail: vectron@vectron.com × <http://www.vectron.com>

*Vectron International, Inc. reserves the right to make changes to the product(s) and/or information contained herein without notice. No liability is assumed as a result of their use or application. No rights under any patent accompany the sale of any such product(s) or information.*